

Select Sheath Mounting or Bend Options as desired from tables below.

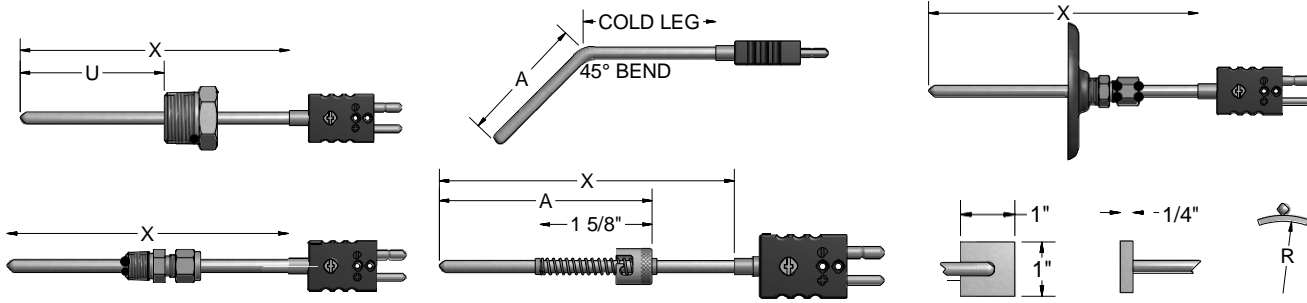

ORDER CODES

2

Example Order Number:

K48GM - 012 - 01A,306

Page MgO-

Page MgO-

Page MgO-

2-1 No Fitting or Bend Options

CODE	00
------	----

2-2 One-Time Adjustable Compression Fittings

CODE	TYPE	NPT SIZE (inches)	PRESSURE RATED	AVAILABLE SHEATH DIAMETERS (inches)
01A	303 Stainless steel	1/8	NO	1/16, 1/8, 3/16, 1/4
05A	316 Stainless steel	1/8	YES	1/16, 1/8, 3/16, 1/4
05B	316 Stainless steel	1/4	YES	1/8, 3/16, 1/4, 3/8
05C	316 Stainless steel	1/2	YES	1/8, 1/4, 3/8
15A	Brass	1/8	NO	1/8, 3/16, 1/4
15B	Brass	1/4	NO	3/16, 1/4, 3/8
15C	Brass	1/2	NO	1/4, 3/8

2-3 Re-Adjustable Compression Fittings

CODE	TYPE	NPT SIZE (inches)	AVAILABLE SHEATH DIAMETERS (inches)
10A	303 Stainless steel	1/8	1/16, 1/8, 3/16
10B	303 Stainless steel	1/4	1/4, 3/8
10C	303 Stainless steel	1/2	1/4, 3/8
12A	316 Stainless steel	1/8	1/16, 1/8, 3/16, 1/4
12B	316 Stainless steel	1/4	1/8, 3/16, 1/4, 3/8
12C	316 Stainless steel	1/2	1/8, 1/4, 3/8
11A	Brass	1/8	1/16, 1/8, 3/16, 1/4
11B	Brass	1/4	1/8, 3/16, 1/4, 3/8
11C	Brass	1/2	1/4, 3/8
19C	Spring-loaded SS well fitting	1/2	3/16, 1/4

FEP gland standard 204 °C [400 °F] max. For lava gland 649 °C [1200 °F] max. opt. 10A and 10B only use letter suffix "L" after compression fitting order code. EXAMPLE: 10AL for lava gland.

2-4 Fixed Bushings

CODE	MOUNTING THREAD NPT (inches)	AVAILABLE SHEATH DIAMETERS (inches)
316 SS		
8A __ [1]	1/8	1/16, 1/8, 3/16, 1/4
8B __ [1]	1/4	1/16, 1/8, 3/16, 1/4, 3/8
8C __ [1]	1/2	1/8, 3/16, 1/4, 3/8
8D __ [1]	3/4	1/8, 3/16, 1/4, 3/8

[1] When ordering fixed bushings, specify order code above plus insert length "U", as measured from hot tip to bottom of threaded bushing. EXAMPLE: order code 8A06 is 1/8" NPT, 316 SS bushing located 6" from hot tip.

2-5 Sheath Bends

CODE	DESCRIPTION
2 __	Sheath bent 45°
3 __	Sheath bent 90°

When ordering bend options, specify hot leg dim. "A". EX: order code 206 is a 45° bend with 6" hot leg. Total sheath length in Table 1, referred to as "X" length = hot leg plus cold leg.

2-6 Weld Pads

CODE	DESCRIPTION
17	316 SS weld pad 1" x 1" x 1/4" thick perpendicular mount
18	316 SS weld pad 1" x 1" x 1/4" thick horizontal mount
17R	316 SS weld pad 1" x 1" x 1/8" thick perpendicular mount with radius bend (specify radius)
18R	316 SS weld pad 1" x 1" x 1/8" thick horizontal mount with radius bend (specify radius)

2-7 Miscellaneous Options

CODE	DESCRIPTION	AVAILABLE SHEATH DIAMETERS (inches)
13A __ [1]	Spring-loaded bayonet fitting	1/8, 3/16
14	Adjustable flange with brass compression fitting	1/8, 3/16, 1/4, 3/8
16A	Compression fitting with bayonet cap and spring	1/8 (2 5/8" min. "A" dim.)

[1] When ordering fixed bayonet fitting, specify hot leg dimension "A". EXAMPLE: order code 13A06 for a fixed bayonet adapter with 6" hot leg. Total sheath length is Table 1 "X" length = hot leg plus cold leg.